

Multiple Chemical Sensitivity:
Toxicological and Sensitivity Mechanisms

Martin L. Pall

Professor Emeritus of Biochemistry and Basic Medical Sciences,
Washington State University and Research Director, The Tenth
Paradigm Research Group
638 NE 41st Ave.
Portland, OR 97232-3312 USA

503-232-3883

martin_pall@wsu.edu

Abstract:

Cases of multiple chemical sensitivity (MCS) are reported to be initiated by seven classes of chemicals. Each of the seven acts along a specific pathway, indirectly producing increases in NMDA activity in the mammalian body. Members of each of these seven classes have their toxicant responses lowered by NMDA antagonists, showing that the NMDA response is important for the toxic actions of these chemicals. The role of these chemicals acting as toxicants, in initiating cases of MCS has been confirmed by genetic evidence showing that six genes that influence the metabolism of these chemicals, all influence susceptibility to MCS. It is likely that chemicals act along these same pathways, leading to increased NMDA activity when they trigger sensitivity responses in MCS patients.

The chronic nature of MCS and also related multisystem illnesses is thought to be produced by a biochemical vicious cycle mechanism, the NO/ONOO- cycle, which is initiated by various stressors that increase nitric oxide and peroxynitrite levels (with some but not others acting via NMDA stimulation). The NO/ONOO- cycle is based on well documented individual mechanisms. The interaction of this cycle with previously documented MCS mechanisms, notably neural sensitization and neurogenic inflammation, explains many of the previously unexplained properties of MCS. This overall mechanism is also supported by physiological correlates found in MCS and related multisystem illnesses, objectively measurable responses to low level chemical exposure in MCS patients, many studies of apparent animal models of MCS and also evidence from therapeutic trials of MCS-related illnesses. Some have argued that MCS is a psychogenic illness, but this view is completely inconsistent with this diverse data on MCS and related illnesses and the literature claiming psychogenesis of MCS

is deeply flawed. In addition, two rare predictions that can be used to test psychogenesis both lead to rejection of the psychogenic hypothesis. While the NO/ONOO- cycle mechanism for MCS is supported by many different observations, there are also multiple areas where further study is needed.

Key Words: Peroxynitrite; oxidative stress; excitotoxicity; mitochondrial dysfunction; long term potentiation; chronic fatigue syndrome/myalgic encephalomyelitis; fibromyalgia

Introduction

Multiple chemical sensitivity (1) (MCS), also known as chemical intolerance, multiple chemical sensitivities, chemical sensitivity, or toxicant induced loss of tolerance (TILT) is an illness or disease where previous chemical exposure appears to initiate the wide ranging sensitivities characteristic of MCS. The inference that cases of MCS are initiated by previous chemical exposure is implied by the TILT name (2). Case initiation by such previous chemical exposure was also a requirement for a person to fit the Cullen case definition (3) for MCS. The role of previous chemical exposures is widely discussed in the influential Ashford and Miller book which reviewed MCS (4) and at least 50 studies have shown that such previous chemical exposure is characteristic of and appears to initiate most MCS cases (reviewed in 1,4-6). Some have claimed that MCS is a psychogenic illness and have advocated the name idiopathic environmental intolerance (IEI). This name argues, in essence, that chemical exposure is not involved in initiating such sensitivity and that we have no idea what the cause may be, that is that it is idiopathic. Both of these contentions have been vigorously challenged (1). This paper is primarily a separately written and much shorter version of reference 1 and the reader is referred to that study for a much more extensive documentation of many of the observations contained below.

What Types of Chemicals Initiate Cases of MCS and How Can They Act as Toxicants?

Perhaps the largest single challenge in understanding MCS is how can the diverse chemicals implicated in initiating cases of MCS and triggering sensitivity symptoms in those already sensitive act to produce a common response in the body? The MCS skeptic, Ronald Gots has challenged MCS researchers, arguing that the diverse types of chemicals reportedly involved cannot possibly produce a common

response (7). Certainly in order to develop a compelling model for MCS, we need to meet this challenge (Fig. 1).

Pesticide and Organic Solvent Action in MCS

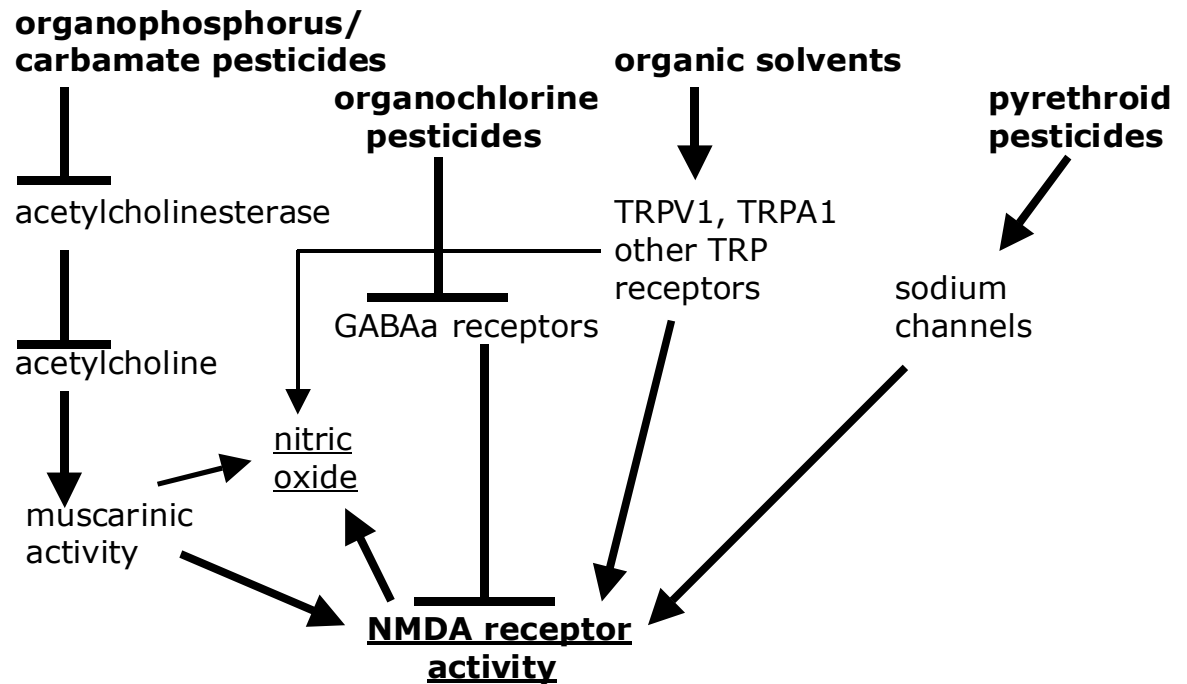

Figure 1

Each of the arrows represents a mechanism whereby one element of the figure stimulates another. The upside down T's represent inhibitory mechanisms. It can be seen that each of the four classes of compounds leads to increased NMDA activity via the pathways diagrammed above. The specific mechanisms diagrammed in this figure are discussed in some detail in references 1 and 5.

The main classes of chemicals that initiate cases of MCS are the very large class of organic solvents and related compounds and three classes of pesticides (1,4,5,6,8). The pesticides include the often reported classes of organophosphorus and carbamate pesticides (1,4,5,8), the organochlorine pesticides (1,4) and the pyrethroid pesticides (1,4). These four classes of compounds can all produce a common response in the body, increasing the activity of the NMDA receptors (Fig. 1 and refs. 1,5).

Other types of chemicals reported to initiate cases of MCS include mercury, hydrogen sulfide and carbon monoxide (reviewed in 1). These three (with mercury acting through its product methylmercury) all produce increases in NMDA activity, as well (1). Furthermore, there is data from animal models that members of all seven of these classes of chemicals can have their toxic responses greatly lowered by using NMDA antagonists (1). This shows that not only do members of these classes of chemicals act to produce an increase in NMDA activity, but that the increase has a major role, probably the major role, in the toxic response to these chemicals.

So there is a compelling solution to what is arguably the largest single challenge in understanding the mechanism of MCS, namely that all seven classes of these chemicals act to produce a common response in the body, increased activity of the NMDA receptors.

There are six other types of evidence implicating elevated NMDA activity in MCS (1,5,9,10). These include clinical observations that the NMDA antagonist dextromethorphan can substantially lower reactions of MCS cases to chemical exposure (1,9,10). This specific observation suggests that in people who have become chemically sensitive, chemicals triggering such sensitivity reactions also act to increase NMDA activity. In other words, both initiating chemicals and chemicals triggering sensitivity responses may well act along exactly the same pathways. The sensitivity of MCS patients to monosodium glutamate (9,10), an NMDA agonist, also suggests a role of elevated sensitivity to agents acting via the NMDA receptors, in the chronic phase of MCS.

Is There Other Evidence that Initiating Chemicals Act as Toxicants in MCS?

We have, then, compelling evidence that chemicals act to initiate cases of MCS and that each class of such chemicals produces a common

Table 1. Genetic Polymorphisms Influencing MCS Susceptibility

Gene	Study	Function- chemical metabolism	Comments
PON1	H,M	Detoxification of organophosphorus toxicants including pesticides	
CYP2D6	M	Hydroxylation of hydrophobic compounds	May be expected to increase activity of strictly hydrophobic solvents on the TRPV1 receptor
NAT2	M,S	Acetylation	May produce more or less activity, depending on substrate
GSTM1	S	Provides reduced glutathione for conjugation	Should increase detoxification and excretion
GSTT1	S	Glutathione conjugation	Should increase detoxification and excretion
UGT1A1	M&S	Glucuronidation, leading to increased excretion	

H=Haley et al, 1999 (11); M=McKeown-Eyssen et al, 2004 (12); S=Schnakenberg et al, 2007 (13); M&S= Müller and Schnakenberg, 2008 (14).

toxic response in the body, characterized by elevation of NMDA activity.

The role of chemicals acting as toxicants in MCS has been confirmed by a series of compelling studies showing that genes that help determine the metabolism of such chemicals influence susceptibility to MCS (reviewed in 1), see Table 1.

In these four studies (11-14), a total of six genes whose products have roles in the metabolism of organic solvents and related compounds, and in some cases the metabolism of pesticides, influence susceptibility (Table 1). The data showing that four of these genes, studied in the S and M&S papers (13,14) help determine susceptibility and have very high levels of statistical significance, strongly arguing that these

associations are not caused by a statistical fluke. The data from the other two studies, implicating three genes, are statistically significant, as well (Table 1). There is only one interpretation that is compatible with such a role for all six of these genes. It is that chemicals act as toxicants in the initiation of MCS and that consequently, enzymes that influence the metabolism of these compounds, converting them into either less or more active compounds, determine how susceptible each individual is to being initiated with a case of MCS (1,4). These are all apparent gene X environment interactions such that the role of specific polymorphic genes will be influenced by the chemical exposure of specific populations. Consequently, we should not expect that all populations will show the same patterns of genetic susceptibility because they differ from one another in chemical exposure patterns.

Since the Nobel prize winning studies of Beadle and Tatum in the 1940's it has been clear that genetics is THE most powerful approach towards determining biological mechanism. It follows from the genetic studies summarized in Table 1, and the common action of apparent initiating chemicals producing a toxic response (via increased NMDA activity) that is otherwise implicated in MCS, that the role of chemicals acting as toxicants in MCS is undeniable.

MCS Is a Reaction to Chemicals, Not Odors

It should be clear from the above, that chemicals acting in MCS are not acting on the classic olfactory receptors (15,16), but rather are acting as toxicants. This is opposite many published but undocumented claims that MCS is a response to odors. There is additional evidence arguing against the view that MCS is a reaction to odors. MCS sufferers who are anosmic, having no sense of smell, people who have intense nasal congestion and people whose nasal epithelia have been blocked off with nose clips can all be highly chemically sensitive (1,4). This does not necessarily mean that MCS never impacts the olfactory system. It simply means that MCS is not primarily an olfactory response. A recent study, confirmed this view, showing that the olfactory center in the brain in people with MCS was less sensitive to activation by chemical exposure than in normal controls, rather than being more sensitive (17).

What Causes the Chronic Nature of MCS ?

The initiation of cases of MCS via chemicals acting to increase excessive NMDA activity is important, and it raises two additional important questions: Why is MCS chronic? And how does this chronic

illness generate the symptoms of MCS including the exquisite high level sensitivity to this group of chemicals? Let's consider the first question first.

Figure 2. Updated version of NO/ONOO- cycle

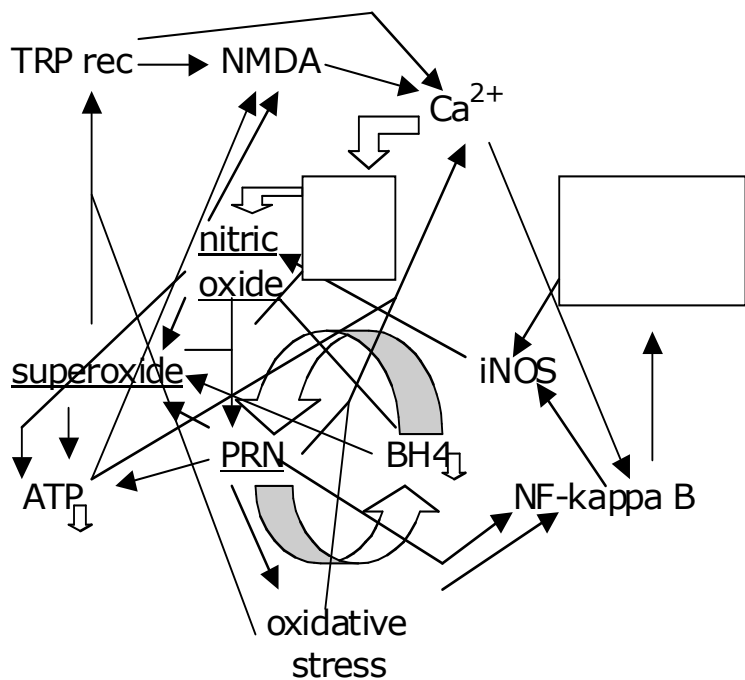

Each arrow represents one or more mechanisms by which the variable at the foot of the arrow can stimulate the level of the variable at the head of the arrow. It can be seen that these arrows form a series of loops that can potentially continue to stimulate each other. An example of this would be that nitric oxide can increase peroxynitrite (abbreviated PRN) which can stimulate oxidative stress which can stimulate NF- κ B which can increase the production of iNOS which can, in turn increase nitric oxide. This loop alone constitutes a potential vicious cycle and there are a number of other loops, diagrammed in the figure that can collectively make up a much larger vicious cycle. You will note that the cycle not only includes the compounds nitric oxide, superoxide and peroxynitrite but a series of other elements, including the transcription factor NF- κ B, oxidative stress, inflammatory cytokines (in box, upper right), the three different forms of the enzymes that make nitric oxide (the nitric oxide synthases iNOS, nNOS and eNOS), and two types of neurological receptors, some of the TRP group of receptors and the NMDA receptors. Central to the figure are the reciprocal interactions between peroxynitrite, abbreviated as PRN and tetrahydrobiopterin (BH4) depletion. Also indicated is the ATP (energy) depletion produced by the impacts of peroxynitrite, superoxide and nitric oxide on mitochondrial function.

Increased NMDA activity is known to produce increased calcium influx into cells, leading to increased activity of two calcium-dependent nitric oxide synthases, nNOS and eNOS, which produce, in turn increased nitric oxide (1,18,19). Nitric oxide reacts with superoxide to form peroxynitrite, a potent oxidant (1,18,19). Peroxynitrite is thought to initiate a complex biochemical vicious cycle, known as the NO/ONOO⁻ cycle (Fig. 2), which is responsible for the etiology of not only MCS, but also such related and comorbid diseases as chronic fatigue syndrome, fibromyalgia and post-traumatic stress disorder (1,5,20,21). The cycle is named for the structures of nitric oxide (NO) and peroxynitrite (ONOO⁻) but is pronounced “no, oh no!” because this is the way sufferers feel when they are afflicted by these chronic diseases. The latest version of the cycle is diagrammed in Fig.2 (1, 21). It can be seen (Fig.2) that the NO/ONOO⁻ cycle is actually an interacting series of cycles, and the combination of all of these cycles is thought to make the NO/ONOO⁻ cycle difficult to down-regulate, thus producing challenges for therapy that aims at lowering the basic cause.

The basic concept here, is actually quite simple. Initiating stressors act mainly through peroxynitrite, to initiate the cycle and once the cycle is initiated, IT IS the CAUSE of ILLNESS. That is these diseases, which typically last for decades and often for life, are produced by the NO/ONOO⁻ cycle, with the initiating stressor often being long gone. While there are some chronic stressors involved in initiating these diseases, most are short-term stressors whose role is to initiate the cycle.

The various elements of the cycle are linked to each other by arrows, with each arrow representing one or more mechanisms by which one element of the cycle increases another. Each of these mechanisms, and 30 are represented in Fig. 2 (1,5,21), are well-documented mechanisms, most of which have been demonstrated to have measurable roles in genuine pathophysiological conditions. Thus there is nothing new in terms of individual mechanisms in the cycle, and the only new inferences seen here are a consequence of their various interactions seen in the NO/ONOO⁻ cycle.

Initiating Stressors

A series of initiating stressors that are reported to initiate cases of MCS and also three other related multisystem illnesses are listed in Table 2. These four illnesses, chronic fatigue syndrome/myalgic encephalomyelitis, MCS, fibromyalgia and post-traumatic stress

disorder all share many symptoms in common, are commonly comorbid and all share a common pattern of case initiation, with cases initiated by several short term stressors which produce, then, subsequent chronic illness. Many scientists have suggested that two, three or all four of these these may share a common etiology (1,5) and it is argued here and elsewhere (1,5,20,21), that what we call the NO/ONOO- cycle is the etiologic mechanism.

Table 2: The Stressors Implicated in the Literature in the initiation of these illnesses.

Illness	Stressors Implicated in Initiation of Illness
Chronic fatigue syndrome/myalgic encephalomyelitis (CFS/ME)	Viral infection, bacterial infection, organophosphorus pesticide exposure, carbon monoxide exposure, ciguatoxin poisoning, physical trauma, severe psychological stress, toxoplasmosis (protozoan) infection, ionizing radiation exposure
Multiple chemical sensitivity	Volatile organic solvent exposure, organophosphorus/carbamate pesticide exposure, organochlorine pesticide exposure, pyrethroid exposure; hydrogen sulfide; carbon monoxide; mercury
Fibromyalgia	Physical trauma (particularly head and neck trauma), viral infection, bacterial infection, severe psychological stress, pre-existing autoimmune disease
Post-traumatic stress disorder	Severe psychological stress, physical (head) trauma

The stressors indicated in bold are the ones most commonly implicated for that specific disease/illness. It should be noted that the majority of such stressors are implicated in the initiation of more than one illness.

It has already been noted that all of the chemicals implicated in MCS initiation act to increase nitric oxide levels via increased NMDA activity. However, several initiators for CFS/ME and fibromyalgia do not act to increase NMDA activity. Specifically the infections which are commonly involved in initiating cases of CFS/ME and also fibromyalgia act via induction of the inducible nitric oxide synthase (iNOS) (5). Ionizing radiation which also initiates cases of CFS/ME-like illness also act via iNOS induction (20). It follows that increased NMDA activity is not apparently required to initiate the NO/ONOO- cycle but nitric oxide and especially its product peroxynitrite increases may be required.

This pattern suggests that there may be a specific requirement for increased NMDA activity for MCS initiation but not for CFS/ME or fibromyalgia initiation. We will return to why this may be the case below.

Five Principles

There are five principles underlying the NO/ONOO- cycle as an explanatory model:

1. Short-term stressors that initiate cases of multisystem illnesses act by raising nitric oxide and/or other cycle elements.
2. Initiation is converted into a chronic illness through the action of vicious cycle mechanisms, through which chronic elevation of peroxynitrite and other cycle elements is produced and maintained. This principle predicts that the various elements of the NO/ONOO- cycle will be elevated in the chronic phase of illness.
3. Symptoms and signs of these illnesses are generated by elevated levels of nitric oxide and/or other important consequences of the proposed mechanism, i.e. elevated levels of peroxynitrite or inflammatory cytokines, oxidative stress, elevated NMDA and TRPV1 receptor activity, ATP and BH4 depletion and others.
4. Because the compounds involved, nitric oxide, superoxide and peroxynitrite have quite limited diffusion distances in biological tissues and because the mechanisms involved in the cycle act at the level of individual cells, the fundamental mechanisms are local.^{*} The consequences of this primarily local mechanism show up in the multisystem illnesses through the stunning variations one sees in symptoms and signs from one patient to another. Different tissue impact of the NO/ONOO- cycle mechanism is predicted to lead to exactly such variations in symptoms and signs.

* There are some systemic effects in addition to the local mechanisms, including antioxidant depletion, inflammatory cytokine action, neuroendocrine dysfunction and possibly BH4 depletion.

One also sees evidence for this fourth principle in MCS and related multisystem illnesses from published brain scan studies (17,22-26) where one can directly visualize the variable tissue distribution in the brains of patients suffering from MCS or one of these related illnesses (1,5,20). This principle also explains the stunning variation that sufferers of each of these illnesses report in severity and also in their symptoms and signs (1,4, 27).

5. Therapy should focus on down-regulating the NO/ONOO- cycle biochemistry. In other words, we should be treating the cause, not just the symptoms

It can be seen that these five principles collectively produce a nearly complete explanatory model of NO/ONOO- cycle diseases. We have already discussed, above, evidence for fit to the first principle in the case of MCS. Evidence for a fit to all five principles for MCS is provided in 1,9,10,28 and also Chapter 7, ref. 5. Such evidence will be discussed more briefly below.

The fit to each of these five principles, for a specific disease/illness, provides a very distinct type of evidence that that disease/illness is a NO/ONOO- cycle disease. Because of this, each of the five principles serve as a criterion for deciding whether a specific disease/illness is a good candidate for inclusion under the NO/ONOO- cycle disease mechanism. In this way, the five principles serve for NO/ONOO- cycle diseases, somewhat like Koch's postulates do for infectious diseases.

Case Definitions

There has been a lot of interest in case definitions for MCS because of concern about whether different studies of "MCS" are studying the same patient population. In a review of different case definitions (29), it appeared that the 1999 consensus case definition (30) was probably the best available such case definition but two modest changes may be improvements (1). Having said that, the most important thing about standardizing patient studies may be to limit the huge range of severity among cases of MCS in such studies and possibly also the variation of tissue impact of sensitivity responses. It can be argued that studies should focus on the most sensitive quarter of MCS patients because differences of less severely affected patients when compared with controls will be more difficult to measure (1).

Prevalence Estimates

There have been a number of prevalence estimates of MCS that have been reviewed elsewhere (1,5,27). The prevalence of severe MCS in the U.S, is approximately 3.5% of the population, with much larger numbers, possibly 12 to 25% moderately affected (1,5). The most extensive such studies have been published in a series of papers by Caress and Steinemann (31). Studies from Canada, Germany, Denmark and Sweden have produced similar to somewhat lower estimated prevalences, roughly 50 to 100% of the U.S. estimates (1). From these various studies, MCS appears to have a very high prevalence, even higher than that of diabetes. Four studies report that there is also high comorbidity between MCS and important chronic diseases (32-35), providing further evidence that the public health impact of MCS is immense.

Some Possible Mechanisms for Shared Symptoms and Signs

While the symptoms of MCS, CFS/ME, fibromyalgia and PTSD are highly variable from one patient to another, these four illnesses share a series of symptoms and signs that were reviewed earlier (5). Each of them can be explained as being a consequence of NO/ONOO- cycle elements, in many cases as a consequence of their impact on certain regions of the body (Table 3).

Table 3 Explanations for Symptoms and Signs

Symptom/ Sign	Explanation based on elevated nitric oxide/peroxynitrite theory
energy metabolism /mitochondrial dysfunction	Inactivation of several proteins in the mitochondrion by peroxynitrite; inhibition of some mitochondrial enzymes by nitric oxide and superoxide; NAD/NADH depletion; cardiolipin oxidation
oxidative stress	Peroxynitrite, superoxide and other oxidants
PET scan changes	Energy metabolism dysfunction leading to change transport of probe; changes in perfusion by nitric oxide, peroxynitrite and isoprostanes; increased neuronal activity in short-term response to chemical exposure
SPECT scan changes	Depletion of reduced glutathione by oxidative stress; perfusion changes as under PET scan changes
Low NK cell function	Superoxide and other oxidants acting to lower NK cell function
Other immune dysfunction	Sensitivity to oxidative stress; chronic inflammatory cytokine elevation

Elevated cytokines	NF-kappaB stimulating of the activity of inflammatory cytokine genes
Anxiety	Excessive NMDA activity in the amygdala
Depression	Elevated nitric oxide leading to depression; cytokines and NMDA increases acting in part or in whole via nitric oxide.
Rage	Excessive NMDA activity in the periaqueductal gray region of the midbrain
Cognitive/ learning and memory dysfunction	Lowered energy metabolism in the brain, which is very susceptible to such changes; excessive NMDA activity and nitric oxide levels and their effects of learning and memory
Multiorgan pain	All components of cycle have a role, acting in part through nitric oxide and cyclic GMP elevation
Fatigue	Energy metabolism dysfunction
Sleep disturbance	Sleep impacted by inflammatory cytokines, NF-kappaB activity and nitric oxide
Orthostatic intolerance	Two mechanisms: Nitric oxide-mediated vasodilation leading to blood pooling in the lower body; nitric oxide-mediated sympathetic nervous system dysfunction
Irritable bowel syndrome	Sensitivity and other changes produced by excessive vanilloid and NMDA activity, increased nitric oxide
Intestinal permeabilization leading to food allergies	Permeabilization produced by excessive nitric oxide, inflammatory cytokines, NF-κB activity and peroxynitrite; peroxynitrite acts in part by stimulating poly(ADP)-ribose polymerase activity

It should be noted that while each of these are plausible mechanisms and, in most cases well-documented mechanisms under some pathophysiological circumstances, in most cases their role in generating these symptoms in these multisystem illnesses is not established.

The mechanisms outlined in Table 3 are *not* established mechanisms *in these illnesses*. Nevertheless, they provide evidence that there are such plausible mechanisms for the generation of these symptoms and signs that are consistent with the NO/ONOO- cycle mechanism.

Neural Sensitization and a Fusion Model of MCS

Dr. Iris Bell and her colleagues (36-39) and also others (27,40,41) have proposed that neural sensitization in response to chemical

exposure may be the central mechanism of chemical sensitivity coming from the brain, acting especially in the limbic system. The ten "striking similarities" between neural sensitization and MCS discussed in Ashford and Miller (4) may be the best summary of the types of evidence originally supporting this view.

The probable mechanism of such neural sensitization, known as long term potentiation (LTP), is known to involve elevated NMDA activity, as well as several consequences of such NMDA elevation, all NO/ONOO- cycle elements, including elevated intracellular calcium levels, nitric oxide and peroxynitrite (reviewed in 1). It can be argued that the fact that several key elements of the NO/ONOO- cycle have very important roles in LTP is not likely to be coincidental, but rather that what we have acting here is a fusion model of the NO/ONOO- cycle mechanism with the neural sensitization mechanism which explains the properties of central sensitization much better than does either one alone (1,9,10). Increased chemical sensitivity of certain regions of the limbic system has been reported in a recent SPECT scan study comparing MCS patients and controls (17).

The key role of NMDA elevation in LTP and the ability of the various classes of chemicals that initiate cases of MCS to increase NMDA activity must be viewed as a central unifying concept in MCS. High level chemical exposure leading to massive increases in NMDA activity in regions of the brain, as well as massive increases in downstream responses in intracellular calcium, nitric oxide and peroxynitrite, will be expected collectively to produce massive stimulation of LTP. Whereas LTP stimulation is very selectively involved in increasing the sensitivity of specific synapses in learning and memory, such massive stimulation by chemical exposure will be expected to produce pathophysiological responses. Because such massive responses will directly occur only in regions of the brain where such chemical exposure can produce NMDA stimulation, this will lead to high level chemical sensitivity because these are exactly the regions of the brain that will be stimulated by subsequent chemical exposure in those that have been sensitized. One of the assumptions of this model is that there must be substantial overlap in the brain regions stimulated by different classes of chemicals that act along different pathways to produce increases in NMDA activity.

Energy depletion produced by mitochondrial dysfunction as a consequence of elevated levels of peroxynitrite, superoxide and nitric oxide (1,5,9,20) is expected to have a key role in such MCS-related neural sensitization whereas it may have only minor effects in normal

LTP as it acts in learning and memory. When whole regions of the brain are impacted by the the NO/ONOO- cycle, the massive elevation of these compounds over such regions of the brain will be expected to produce much more substantial energy depletion. Energy depletion is known to produce increased NMDA sensitivity via two well established mechanisms. When cells containing such NMDA receptors have lowered energy metabolism, the lowered membrane potential of the cell produces large increases in NMDA sensitivity (9,42-44). Furthermore glutamate, the major physiological NMDA agonist has its extracellular levels lowered after release of the neurotransmitter by transport into glial cells, an energy requiring process (45,46). It follows that energy depletion also produces increased and prolonged NMDA stimulation. These roles of energy depletion may be expected, therefore, to have major roles in MCS but to have little if any role in normal LTP.

The confluences of these NO/ONOO- cycle elements as important influences on LTP produces what has been called a fusion model of MCS (9,10). This fusion model is our best understanding of how the central nervous system-related chemical sensitivity is generated.

MCS patients often report exquisite chemical sensitivity, on the order of 1000 times the sensitivity of normals (5,9) and such high level sensitivity has also been reported in a study of measured sensitivity responses (47). How, then, can such a high level of sensitivity be generated by this fusion model mechanism?

It has been proposed that the cycle acts at several different levels to produce such high level central sensitivity, possibly involving the following mechanisms (1,5):

1. Chemical exposure will stimulate regions of the brain with already existing neural sensitization, with that neural sensitization maintained both by the standard LTP mechanism and by the local elevation of the NO/ONOO- cycle. This combination may be exacerbated by a series of mechanisms each involving elements of the NO/ONOO- cycle, as follows:
2. Nitric oxide acting as a retrograde messenger will act to stimulate further glutamate release by the presynaptic neurons.
3. Energy metabolism dysfunction produced by peroxynitrite, superoxide and nitric oxide, will cause NMDA receptors to be hypersensitive to stimulation. It is known that energy metabolism dysfunction produces a decreased membrane potential which acts, in turn, to cause the NMDA receptors in

- such cells to be hypersensitive to stimulation (reviewed in 9, 42-44).
4. Energy metabolism dysfunction also acts on glial cells which normally rapidly lower extracellular glutamate via energy dependent glutamate transport. Lowered energy metabolism will then lead to increased extracellular glutamate, leading in turn to increased NMDA stimulation (45,46).
 5. Peroxynitrite leads to a partial breakdown of the blood-brain barrier, leading to increased chemical access to the brain (reviewed in 9,10,48). Kuklinski et al (49) have reported blood-brain barrier breakdown in MCS patients and there is also an animal model of MCS in which similar breakdown has been observed (50-52).
 6. Many of the chemicals implicated in MCS are metabolized via cytochrome P450 activities and these enzymes are known to be inhibited by nitric oxide, thus possibly leading to increased accumulation of the active chemical forms (reviewed in 9).
 7. TRPV1, TRPA1 and some other TRP receptors are activated through the action of oxidants, as discussed above, and organic solvents and other agents that act via these TRP receptors such as some mold toxins may be expected to have increased activity due to such TRP receptor activation (1,62).

These are all known mechanisms but they have to be considered as hypothetical here because their roles as important causal mechanisms in producing MCS has not been established.

It should be noted, however, that these various mechanisms will be expected to act in multiplicative fashion, such that relatively modest changes at each level, perhaps on the order of perhaps two-fold to five-fold increases at each level, will when multiplied by each other to easily produce a 1000-fold increase in sensitivity. For example, a three-fold increase of each will produce an increased sensitivity of $3^7=2187$, substantially larger than 1000.

Furthermore, one sees huge ranges in apparent sensitivities in MCS patients, ranges that can be explained by being produced by relatively modest differences in NO/ONOO- cycle activities. Environmental medicine physicians have emphasized for many years, the importance of avoiding chemical exposure in order to avoid up-regulating the MCS mechanism and one can see from the multiplicative nature of these presumed mechanisms, why even minor up-regulation of the NO/ONOO- cycle may be able to produce major increases in sensitivity.

Peripheral Sensitivity Mechanisms

The fourth principle underlying the NO/ONOO- cycle mechanism, discussed above, is that the basic mechanism is local, such that up-regulation of the cycle will impact different tissues in different individuals. In the case of MCS, different patients often show different patterns of sensitivity. For example, Sorg states in her review (27) that "Patients with MCS generally experience a reproducible constellation of symptoms but each patient may have a different set of symptoms to the same chemical."^{#*} In addition to the central sensitivity, discussed in the previous section, peripheral sensitivities occur, involving the upper respiratory tract, asthma-type symptoms, GI tract sensitivities, skin sensitivities and sometimes additional organ sensitivities. Sensitivities to chemicals and other agents in the respiratory tract has often been referred to as reactive airways disease. These all appear to be local mechanisms and the mechanisms of such peripheral sensitivities have been most studied by Meggs and his coworkers (53-57). Meggs has reported a role of neurogenic inflammation in peripheral sensitivity (53-57). Such neurogenic inflammation may be a substantial portion of the NO/ONOO- cycle mechanism. It can be triggered by NO/ONOO- cycle elements including the NMDA and TRPV1 receptors (58-63). Because it produces inflammatory responses, it may be expected to up-regulate the cycle as well (1,5). Neurogenic inflammation stimulation by the NMDA receptors may explain the role of chemicals acting to increase NMDA activity in initiating cases involving peripheral sensitivity. Such NMDA stimulation may be able to increase neurogenic inflammation, thus triggering NO/ONOO- cycle elevation in peripheral tissues.

Peripheral chemical sensitivity and perhaps central sensitivity as well may involve mast cell activation (64-66), a process that is stimulated by two NO/ONOO- cycle elements, TRPV1 activation and NF-kappaB stimulation (67-69).

^{#*} One can make a substantial argument that this observation alone should lead us to a primarily local mechanism for MCS and other multisystem illnesses, such as the NO/ONOO- cycle mechanism. How else can one explain the profound variation in symptoms from one patient to another, other than by a local mechanism with different tissue distribution in different patients? How else can one explain the substantial stability of symptoms in each individual other than by arguing that the local mechanism is a vicious cycle, that propagates itself over time?

In general, when one looks at the possible (probable?) mechanisms leading to high level peripheral sensitivity, many of the mechanisms proposed above for central sensitivity may be expected to be involved. However clearly the blood brain barrier has no role in peripheral sensitivity and the role of nitric oxide acting as a retrograde messenger may be unlikely to have a role. However, neurogenic inflammation and mast cell activation may have substantial roles. So again, sensitivity mechanisms acting multiplicatively at multiple levels may be responsible for the apparent high level sensitivity associated with peripheral tissues.

Summary of Animal Model Data

Ref. 1 reviewed 39 different apparent animal model studies of MCS. A surprisingly large number of NO/ONOO- cycle elements as it is proposed to play out in MCS have been implicated in such animal models (citations provided in reference 1). NO/ONOO- cycle elements as well as their interactions with neural sensitization and neurogenic inflammation mechanisms have been reported to be involved in one or more such animal models:

1. Neural sensitization and cross sensitization (where sensitization to one chemical also produces sensitization to a second chemical).
2. Progressive sensitization, where sensitivity progresses with increasing numbers of chemical exposures.
3. Chemical agents acting via decreased acetylcholinesterase or GABA_A activity or via increased TRPV1 activity or sodium channel activity (see Fig. 1).
4. Oxidative stress.
5. Increased NMDA activity.
6. Increased nitric oxide.
7. Increased peroxynitrite.
8. Elevated inflammatory cytokine levels or levels of other inflammatory markers.
9. Elevated levels of intracellular calcium.
10. Breakdown of the blood brain barrier.
11. Neurogenic inflammation.
12. Airways sensitivity (reactive airways disease).
13. Chemical linkage to the sensory irritation response (thought to involve a number of TRP receptors including TRPV1).

While only a limited number of these have been measured in each animal model, so that one cannot determine whether all of these may be implicated in any single animal model, it is surprising how many aspects of the NO/ONOO- cycle as it is predicted to play out in MCS, are implicated in one or more animal models. In fact, the only major part of the cycle that is not implicated in one or more animal models is BH4 depletion, which has never been measured.

One can, therefore, make a substantial case for the NO/ONOO- cycle as the mechanism of MCS from animal model data alone.

Putative Specific Biomarker Tests Via Objectively Measurable Responses to Chemical Exposure

There are quite a number of studies where objectively measurable responses to chemical exposure differs in comparing MCS patients with controls. In most cases, these involve tests of responses to low level chemical exposure. Clearly one needs to develop specific biomarker tests for MCS, so that tentative diagnoses based on self-reported symptoms can be objectively confirmed via one or more objectively measurable tests. Thus the literature on objectively measurable responses to chemical exposure, where MCS patients differ from normal controls, is of great importance because such responses may be viewed as putative specific biomarker tests.

Table 3, below, summarizes a number of such studies. Only one citation is provided for each type of study and other relevant citations are provided in ref. 1.

Table 3. Possible Specific Biomarker Tests

Specific Test	Comments and Citation
Cough response produced by low level capsaicin challenge	Same pathway proposed to be involved in response to organic solvent exposure, TRPV1 leading to NMDA response (70,71). One study also showed inflammatory response. Studies by Millqvist and coworkers (72).
PET scan study of brain	Elevated responses in some parts of limbic region (17).
EEG changes on chemical exposure	Presumably closely linked to neural sensitization response (73).
Skin conductivity change on chemical exposure	Similar to polygraph ("Lie Detector") test; presumably caused by neural sensitization changes (74).
Blood changes in	Single study by Kimata (66); apparent

histamine, nerve growth factor, other inflammatory markers	inflammatory response.
Nasal lavage studies	Multiple studies of inflammatory changes in the nasal epithelia (75); may be linked to rhinitis response.
Increased sensitivity in isolated white blood cells	Only type of study where the MCS patient does not have to be exposed to chemicals and therefore risk up-regulation of sensitivity (76).

Of these tests, the capsaicin cough response test, the blood histamine, nerve growth factor and other inflammatory marker test of Kimata (66) and the nasal lavage tests may be the easiest to apply in a clinical setting and therefore may be the best as practical specific biomarker tests. Having said that, both the cough response test and the nasal lavage test may only pick up MCS patients with substantial respiratory tract involvement and so may not be helpful in testing for the minority of MCS patients lacking such involvement. The Kimata (66) approach, while promising, has only been studied in one published paper, so clearly we need much more information to determine how reproducible it may be.

The various possible specific biomarker tests summarized in Table 3, all appear to be consistent with the NO/ONOO- cycle mechanism for MCS, as outline elsewhere in this paper. Several of them are consistent with the inflammatory aspects of that mechanism, several appear to be consistent with neural sensitization and one involves the pathway of action predicted for the action of organic solvents in MCS.

The Pattern of Evidence

In (1), evidence is summarized supporting various aspects of the NO/ONOO- cycle as it is thought to play out in MCS. Specifically evidence is summarized providing support for each of the following:

1. Excessive NMDA activity
2. Elevated levels of nitric oxide
3. Elevated iNOS induction
4. Elevated peroxynitrite
5. Breakdown of the blood brain barrier
6. Elevated levels of inflammatory cytokines
7. Elevated TRPV1 activity

8. Mitochondrial/energy metabolism dysfunction
9. Neural sensitization

In total there are 51 distinct types of evidence for involvement of one of these. Although there are quite a number of areas where more research is needed, the total of evidence supporting this model for MCS is quite impressive.

Occupational Chemical Exposure and MCS

There have been very few studies of occupational chemical exposure and MCS. This should not be surprising, because corporations have often been opposed to studies of their employees because such studies might document their potential liability. Nevertheless, there have been a number of such studies that have been published.

Morrow et al (77) reported that approximately 60% of organic solvent exposed workers had MCS-like symptoms. In an important study, occupational medicine patients differed from general patients in responses to the Toronto MCS questionnaire in much the same way that self identified MCS patients did, albeit to a lesser extent (78), suggesting that chemical exposure in the occupational environment may initiate substantial numbers of MCS cases. Zibrowski and Robertson (79) reported increased prevalence of MCS-like symptoms among laboratory technicians exposed to organic solvents as compared with similar laboratory technicians with no apparent exposure. An epidemiological study, estimating the prevalence of MCS in various occupations including those expected to have substantial chemical exposure to classes of chemicals implicated in MCS as a consequence of the occupation, reported increased prevalence of MCS in several occupations involving such chemical exposure, again suggesting a causal role of chemical exposure (80,81). Yu et al (82) found high prevalences of MCS-like symptoms among solvent exposed printing workers as compared with non-chemically exposed controls. Moen et al (83) reported high prevalences of neurological symptoms including MCS-like symptoms among mercury exposed dental technicians. There are at least a dozen studies reporting high prevalences of reactive airways disease, a common aspect of MCS, among workers occupationally exposed to organic solvents.

Therapy

There has been much more study of therapy of the related illnesses, CFS/ME and fibromyalgia than for MCS. Within the CFS /fibromyalgia group of illnesses, there is evidence for roles of each of the following mechanisms based on the probable mechanisms of action of individual agents in clinical trials (1,5,20):

- Oxidative stress
- Mitochondrial dysfunction
- Inflammatory biochemistry
- Elevated levels of nitric oxide
- Excessive NMDA activity
- Tetrahydrobiopterin depletion

It follows from this, that much of the NO/ONOO- cycle mechanism is implicated from clinical trial data alone. Five treatment protocols are discussed in Chapter 15, reference 5, that seem to be considerably more effective than are single agents. Each of these involves from 14 to 18 different agents that are predicted to down-regulate the NO/ONOO- cycle biochemistry. One of these, the one the author worked on with Dr. Grace Ziem of Maryland, is the only one that has been studied on chemically sensitive patients (5). Subsequently, the author has developed an entirely over the counter nutritional support protocol with the Allergy Research Group in California. This last protocol appears to produce favorable response in roughly 80-85% of the patients with all three illnesses, albeit with variable responses from one patient to another (1,20). In general these complex treatment protocols produce substantial improvements, but based on the published information on them, none of them produce any substantial numbers of cures. A "best guess" on how to start achieving some substantial numbers of cures is discussed in one paper (20), but whether this will work in practice is currently uncertain.

Psychogenic Claims

Note: This section of this paper uses substantial information from both ref. 1 and from Chapter 13, ref. 5.

There have been over a dozen publications claiming that MCS is some sort of psychogenic illness, generated by some ill-defined psychological mechanism, rather than being a real, physiological illness. There have also been similar claims regarding psychogenesis of the related illnesses, CFS and fibromyalgia.

Such claims on all three illnesses have been reviewed earlier (Chapter 13, ref. 5) and the MCS claims have also been reviewed very recently (1). From a toxicological perspective, claims that MCS is a psychogenic illness are clearly flawed because none of the psychogenic advocates have considered how the chemicals implicated in MCS can act as toxicants in the body. In some cases, psychogenic advocates

dismiss the possible role of chemicals acting as toxicants in MCS, providing little or no evidence to support their case. For example, Binder and Campbell (84) argue that the chemicals implicated in MCS are "not neurotoxins", citing a single irrelevant paper by a psychogenic advocate as their sole support for this claim. They would have their readers believe that none of the hundreds of studies showing that organic solvents and pesticides are neurotoxicants cited, for example, in Kilburne (85), Feldman (86), Marrs and Ballantyne (87) and ref. 1 do not exist.

Such psychogenic claims are also obviously flawed because they are incompatible with the roles of excessive NMDA activity, oxidative stress, neural sensitization, neurogenic inflammation, inflammatory biochemistry, elevated peroxynitrite and many other aspects of the apparent MCS mechanism. They are incompatible with the various physiological changes shown to be involved in animal model studies. They are incompatible with the various studies on objectively measurable changes in response to chemical exposure. Most importantly, they are incompatible with the compelling genetic data that genes that influence the rates of metabolism of chemicals otherwise implicated in MCS, influence susceptibility to MCS. Generally, what psychogenic advocates do is to simply ignore the existence of all of these studies. Wherever data exists clearly contradicting their views, they simply pretend it does not exist.

The failure to consider obviously relevant and easily accessible information from the scientific literature can be viewed as more than sufficient reason to reject psychogenic claims of MCS. Clearly one cannot claim to be doing science while simultaneously ignoring most of the relevant scientific literature. However there are also a number of serious, and in several cases fatal flaws that have been reviewed (1; Chapter 13, ref. 5), that are internal to the structure set up by psychogenic advocates. Let's consider that internal structure and how it apparently plays out in the MCS psychogenic literature.

Psychogenic advocates argue that MCS is simply a belief on the part of those who appear to suffer from it. They claim that this belief is supported, in turn by others, including parents, mistaken health care providers, support groups etc. For example Staudenmayer (88) states in his book that "In my view, EI (the term he uses for MCS) is a disorder of belief". Elsewhere he states that (p. 20 ref. 88) that "The core presupposition of psychogenic theory is that psychological factors are necessary and sufficient to account for the clinical presentations of EI patients. Psychogenic theory emphasizes belief, somatization,

psychophysiological stress and anxiety responses, and psychogenic etiology". It is not uncommon for psychogenic advocates to maintain this view that MCS is caused by belief buttressed by other factors by concluding many "facts" that are not supported by the scientific literature.

For example, Staudenmayer (89) states that "beliefs about low-level, multiple chemical sensitivities as the cause of physical and psychological symptoms are instilled and reinforced by a host of factors including toxicogenic speculation, iatrogenic influence mediated by unsubstantiated diagnostic and treatment practices, patient support/advocacy networks, and social contagion. Intrapsychic factors also reinforce this path through the motivational mechanism of factitious malingering, or unconscious primary and secondary gain, mediated through psychological defenses, particularly projection of cause of illness onto the physical environment." So he is stating that the following nine factors have causal roles in MCS: Belief, toxicogenic speculation, iatrogenic influence, unsubstantiated diagnostic and treatment practices, patient support/advocacy networks, social contagion, factitious malingering, unconscious gain, psychological defenses including projection. So he claims to know that nine distinct but presumably interacting factors have causal roles in MCS. If these nine were measurable physiological/biochemical factors, it would require multiple careful studies on each of the nine in order to establish the causality of each. And with such physiological/biochemical factors, one can often manipulate them directly via specific pharmacological, nutritional and genetic means in humans and/or animal models, allowing one to make compelling arguments for causality. With these psychological factors, one is typically left looking at apparent correlative information and correlation, of course, does not imply causality. So where is the extensive evidence implicating these nine as causal factors in MCS? It does not exist—on any of them. In general, psychogenic advocates feel comfortable making multiple claims when there is little or no scientific support for these claims.

I'd like to convey an account of a personal interaction with psychogenic advocates, this one focused on CFS/ME rather than MCS. Three UK psychiatrists, Stanley, Salmon and Peters wrote an editorial published in the British Journal of General Practice (90), arguing that CFS/ME is a "social epidemic" where symptoms are generated by psychogenic mechanisms. They maintained that these issues "must be interpreted within a rigorous scientific framework". I wrote a letter to the editor (91), listing eight different objectively measurable physiological changes that had been repeatedly found in CFS/ME:

immune (NK cell) dysfunction; elevated levels of inflammatory cytokines, elevated levels of neopterin, elevated levels of oxidative damage, orthostatic intolerance, elevated levels of the 37 kD RNase L, energy metabolism/mitochondrial dysfunction, and neuroendocrine dysfunction. It should be noted that with the exception of the 37 kD RNase L which has never been looked at in MCS, there is published evidence suggesting that the other seven are implicated in MCS as well. I challenged Stanley, Salmon and Peters to show that each of these eight are consistent with their interpretation within a "rigorous scientific framework."

Their response was quite interesting. They stated (92) that there is "no need for us to question the validity of the physiological findings: *if they are correlates or secondary consequences this is entirely consistent with the social origins of persistent unexplained physical symptoms (PUPS)*" (italics added). Basically what they were doing is assuming that their claims are correct and stating that in principle, a number of physiological changes may be produced as an indirect consequence of their claimed "social epidemic". Based on this assumption, they have no qualms in concluding that each of these physiological changes are produced by psychogenic means from such a social epidemic, without one iota of evidence being produced linking any of the eight to a presumed psychogenic mechanism. It should be clear from this that some psychogenic advocates can draw sweeping conclusions based on no evidence whatsoever while still claiming to be acting within a "rigorous scientific framework".

Most psychogenic advocates with the view that MCS and also related multisystem illnesses are caused by belief, justify this view on the intellectual base that it, and also other related multisystem illnesses, are somatoform disorders, presumably involving a process called somatization. Let's look at the definition of these given in Smith (93):

Somatoform: A group of disorders with somatic symptoms that suggest a physical disorder, but for which no organic etiology can be demonstrated. There is presumptive evidence of a psychological basis for the disorder.

Somatization: A process whereby psychological distress is expressed in physical symptoms.

Somatization disorder: A chronic, relapsing psychiatric disorder characterized by at least 13 unexplained medical symptoms from a list

of 37 criteria, with at least one such symptom occurring before the age of 30.

So the overall notion here is that MCS and related multisystem illnesses are a somatoform disorders and possibly a somatization disorders, produced by the process of somatization by which "psychological distress" is expressed in physical symptoms. There are several problematic issues with this framework.

The first of these is that this is inherently based on a dualistic framework. The presumed origin is on the psychological/psychiatric side of that dualism which somehow reaches across the divide through the process of somatization to produce real physical symptoms. However this dualism has been rejected by modern science.

For example, the American Psychiatric Association states in DSM-IV (29, p xxi) "the term mental disorder unfortunately implies a distinction between 'mental' disorders and 'physical' disorders that is a reductionist anachronism of mind/body dualism. A compelling literature documents that there is much 'physical' in 'mental' disorders and much 'mental' in 'physical' disorders." Despite its rejection by modern science, dualistic reasoning has dominated much of the psychogenic literature, causing many problems (see below).

There are other similarly serious problems. The definition of somatoform disorders requires one to document that "no organic etiology can be demonstrated." Even if no such etiology has been demonstrated for a particular illness, the definition requires one to demonstrate that no such etiology can possibly be demonstrated in the future. Typically what psychogenic advocates argue is that no such etiology has been demonstrated, a very different thing. There is a related problem with fulfilling the definition of somatization disorder, where there must be "13 unexplained medical symptoms" in order to meet that definition. What psychogenic advocates have done is to talk about what they claim are "unexplained symptoms" or "medically unexplained symptoms" while not providing one iota of evidence that they are truly unexplained.

The claim that an apparent somatization disorder has multiple unexplained symptoms produces an interesting conundrum. Similarly the claim that a condition is a somatoform disorder, *as it has been dealt with in practice*, presents a similar conundrum. Both of these are based on apparent current ignorance, rather than current knowledge:

ignorance of any current explanation for the symptoms and ignorance of any current pathophysiologic mechanism, respectively. Like many types of ignorance, these are potentially changeable. As a consequence, a condition that is properly classified as a somatization disorder today may not be so properly classified tomorrow as we find symptomatic explanations. Similarly, a condition that is classified as a somatoform disorder today based on the practical definition of lack of physiologically- based etiologic mechanism today, may not be so classified tomorrow, based on finding such a mechanism.

This classification based on current ignorance is very different from the situation with the various well-accepted paradigms of human disease (Chapter 14, ref. 5). If a condition is properly classified today as an infectious disease, hormone dysfunction disease, nutritional deficiency disease or a form of cancer (basically a serial somatic mutation/selection disease), for example, it will still be so classified tomorrow, regardless what new information one obtains about it. Such new information may lead to classification of a disease under a second category but not have it dropped from its initial category. For example, type 1 diabetes was originally found to be a hormone dysfunction disease and this did not change when it was later found to also be an autoimmune disease. It is questionable whether any intellectual structure based on current and potentially changeable ignorance is well constructed.

Of course, I have challenged the notion that we have no etiologic mechanism here as well as the notion that we have no explanations for the symptoms. We have a detailed and generally well supported model for the entire group of multisystem illnesses, the NO/ONOO-cycle model as well as, as you have seen above, explanations for many of the symptoms and signs of these illnesses (1,5). The title of my book (5) is obviously an unmistakable challenge for those who claim that these are unexplained. Psychogenic advocates are free, of course, to criticise either the NO/ONOO- cycle mechanism or the explanations of symptoms and signs derived from it. To date, their response is to pretend that these explanations do not exist. Contrived ignorance is never the basis of good science.

These and other theoretical and practical flaws in the concepts underlying the notion of somatiform disorders and the process of somatization have led others to question the basic concept of somatoform disorders (95-98).

The dualism assumed by psychogenic advocates but rejected by modern science, has often led them to make serious logical flaws in their arguments. Let's look at some examples of these.

Black (99) reported finding a woman who was an apparent MCS patient who he reported responded favorably to treatment with a drug that has been used to treat psychiatric disease, paroxetine. He goes on to state (99) that "This case joins two others (he provides two citations) in showing that some patients diagnosed with multiple chemical sensitivity syndrome have an underlying psychiatric disorder that, when identified, responds to medication therapy." Black assumes that this drug, because it has been used to treat a psychiatric disorder, can only act on psychiatric disorders in the body. The notion that all drugs act to modify the biochemistry and physiology of the body and that none of them magically affect psychiatry seems to be lost on Black. Black has been apparently so immersed in an assumed dualism that he cannot apparently imagine that the biochemical/physiological changes produced by this drug might act on MCS via a mechanism independent of any psychiatric disorder. In fact the drug paroxetine has been shown to lower nitric oxide levels (Chapter 6, ref. 5) and this may suggest a mechanism of action here.

Gots (7) paper on MCS is filled with dualistic reasoning. In it he writes: "Stimulation of a neurotransmitter or release of a hormone occurs in response to stimulus. Evidence of response to stress or phobia, such as EEG changes or elevated cortisol levels, helps to describe part of the organic interface between stimulus and response and supplements our knowledge of how the mind produces symptoms. *These responses, however, are not indicative of organic dysfunction and do not eliminate the role of the mind in the phobic or stress response*" (italics added). The author noted (Chapter 13, ref. 5) that "Gots would have us believe that because these are produced in response to psychological stress, cortisol or EEG changes are of no organic consequence, incapable of producing organic dysfunction. Taken to its logical conclusion, this same reasoning would have us believe that if a person responds to psychological stress by committing suicide, he or she is not 'organically' dead." Gots (7) and other psychogenic advocates suggest where some of their commitment to this discarded dualism comes from. Gots (7) writes that "Manufacturers cannot be held responsible for responses that depend on psychological processes." Issues of possible liability for the initiation of MCS cases are often discussed in the publications of psychogenic advocates and they consistently argue against any such

liability. Is their role biased due to their roles as "expert witnesses" in such liability trials?

One of the strangest logical flaws that come from this assumed dualism is the complete discounting of objectively measurable signs in these multisystem illnesses when somewhat similar signs occur in what are classified as one or more psychiatric illnesses. For example, Binder and Campbell (84) dismiss the biological importance of neuroendocrine abnormalities in fibromyalgia because somewhat similar changes have been reported in people with "emotional problems." They dismiss changed SPECT scan studies demonstrating changes in blood flow to the fibromyalgia patients because "similar problems are nonspecific and occur in psychiatric patients." They dismiss changed SPECT scan patterns in CFS patients because "the abnormalities are nonspecific and similar to those found in psychiatric groups." It should be noted that there are also changes in PET scans and SPECT scans found in MCS patients (1) and one suspects that Binder and Campbell would dismiss these as well. The notion that such objectively measurable changes are important clues to the pathophysiology of these diseases, whether they are specific or nonspecific and whether the diseases are classified as psychiatric or not, seems to be completely lost on Binder and Campbell (84). Rather they argue, in effect, for some kind of guilt by association, where a sign associated with a psychiatric illness is forever stripped of its physiological significance, wherever it may occur.

A similar guilt by association argument was made by Das-Munshi et al (100), who discounted findings of lymphocyte depletion in people with MCS in a study by Baines et al (101) because "this is also known to occur in major depression, possibly as a result of hypercortisolaemia, and widespread immunological differences have also been shown in people with somatization disorders." The Das-Munshi et al (100) claims had two additional errors: They claimed that there was only a non-significant trend towards such lymphocyte depletion, but Baines et al (101) showed the result was highly significant ($p < 0.001$). Furthermore their failure to discuss other objectively measurable changes in MCS suggests that this is the only such change, which of course is nonsense.

One of the challenges that faces psychogenic advocates is the long history of false psychogenic attribution in medicine. In Chapter 13 of my book (5), I reviewed claims of such false psychogenic attribution for nine different diseases:

1. Multiple sclerosis (MS)
2. Parkinson's disease
3. Lupus
4. Interstitial cystitis
5. Migraine
6. Rheumatoid arthritis
7. Asthma
8. Gastric and duodenal ulcers
9. Ulcerative colitis

Each of these has been shown, of course, to be a real physiological disease, caused by genuine demonstrable pathophysiologic mechanisms. The psychogenic claim from that list that has been most recently debunked is #8, ulcers, for which two physicians from Australia, Robin Warren and Barry Marshall won the 2005 Nobel prize in physiology and medicine. They showed that the bacterium Helicobacter pylori plays a key role in the development of both types of ulcers. Ulcers are a bacterial inflammatory disease, with ulcers being produced when the inflammation produced by a Helicobacter infection becomes severe.

Psychogenic advocates clearly need to consider the flaws that generated these earlier psychogenic claims in order to determine whether or not they are making similarly flawed arguments, but to my knowledge, none have done so.

When one looks at the history of these false psychogenic claims, as the evidence for genuine physiological changes in these diseases became more compelling, they often switched their claims to what is now called a "biopsychosocial model". There is evidence suggesting that a number of psychogenic advocates of MCS and other multisystem illnesses are doing that now.

Wessely and his colleagues in the UK have taken a similar tack (102) following the earlier arguments of Barsky and Borus (103). They have proposed the concept of "functional somatic syndromes", FSS, stating that "Of itself, this term tells us nothing about etiology—in particular

there is no implication that these symptoms arise through the hypothetical process of somatization. Simply put, these are clusters of physical symptoms occurring together for which no adequate medical explanation has been found." Of course, my view is that this last position is highly questionable. The group of illnesses they suggest as candidates for FSS most or all may be explainable by the NO/ONOO-cycle mechanism. Later on they ask whether these are all psychosomatic (102), answering their own question with a no but then adding "even if, as seems probable, psychosocial is relevant to the etiology, pathophysiology and management of FSS."

There is one area where Wessely and his colleagues are in good agreement with many who advocate physiological mechanisms for CFS, MCS, fibromyalgia and probably a number of other illnesses (104). They all agree that these various illnesses probably share a common etiology (reviewed in Chapter 1, ref. 5).

There are two key flaws which prevent one from taking either the biopsychosocial or the similar (identical?) FSS approach seriously. The most important of these is that neither provides us with clear testable predictions by which a specific type of illness can be distinguished as being biopsychosocial and/or FSS rather than having a more strictly physiological mechanism. The somatoform disorder/somatization structure at least does provide such predictions, even if these are seldom if ever analyzed in practice. Thus the biopsychosocial/FSS views should be currently classified as a mythology rather than being a testable scientific hypothesis. The second is that they are often interpreted by the medical community as being psychological/psychiatric in nature, but for some reason, cannot be fully documented as such. That is they are often viewed with a wink and a nod. This interpretation is often encouraged by their advocates. For example, Binder and Campbell (84) start out their paper arguing for a biopsychosocial "mechanism" but write the rest of the paper, as if the illnesses discussed were strictly psychological/psychiatric. The quotation from two paragraphs above suggests a similar interpretation on the part of Wessely and his colleagues for FSS. One cannot help wondering whether the criticism that Staudenmayer levels against those arguing for a physiological mechanism for MCS (p. 39, ref. 88) may be more relevant in looking at biopsychosocial or FSS advocates. He argues that "In pseudoscience, in particular, refutation generates new and even less testable hypotheses."

One of the most important obligations that we have as scientists, is to objectively assess the scientific literature in our publications. Having seen the many examples, above, in which psychogenic advocates have ignored a wide variety of evidence that should lead to rejection of their claims, it will not be a surprise that they have consistently failed to do so. Before leaving this area of concern, it is useful to consider still another such example.

Perhaps the most serious failure to objectively assess the scientific literature from psychogenic advocates of MCS is the Staudenmayer et al (105) paper (reviewed earlier in (1) and Chapter 13, ref. 5) that purports to look at the evidence for fulfilling the Hill (106) criteria for chemical exposure in MCS. The Hill criteria are a set of nine criteria that were developed to assess the issue of environmental causation of a possibly environmentally caused illness. For MCS, the issue is whether chemical exposure is likely to initiate cases of MCS. This issue was considered earlier by Ashford and Miller (pp. 273-275, ref. 4), who came to the conclusion in their influential and widely cited book that there was good evidence for fulfilling six of the nine Hill criteria for chemical causation of MCS. Staudenmayer et al (105), in their "evidence-based review" were apparently completely unaware of the previous Ashford and Miller (4) analysis and were also apparently completely unaware of any of the studies cited by Ashford and Miller in support of their conclusions. Staudenmayer et al (105) concluded (p.244) that "toxicogenic theory fails to meet any of the nine Hill criteria."

Possibly the most egregious failure of Staudenmayer et al (105) to objectively assess the scientific literature, comes in their discussion of the fourth Hill (106) criterion. This is the criterion of temporality, does chemical exposure precede or follow the initiation of cases of MCS? As was noted earlier in this paper, there are at least 50 studies reporting that chemical exposure typically precedes case initiation in MCS, and yet Staudenmayer et al (105) were apparently unable to find even one of these, in their "evidence-based review". Several of these are both highly cited and obviously relevant. For example, the Miller and Mitzel (8) study compared MCS patients that had been apparently initiated by previous exposure to outgassing of organic solvents in recently remodeled buildings with those apparently initiated by previous pesticide exposure, predominantly organophosphorus pesticides. The relevance of this paper to the fourth Hill criterion is obvious from its title, but Staudenmayer et al (105) were apparently unable to find it, despite its having been cited at least 50 times (Chapter 13, ref.5) before the Staudenmayer et al paper (105) was submitted. There is

evidence, ranging from compelling to relatively weak for fulfilling the other eight Hill criteria for chemical causation of MCS (Chapter 13, ref. 5), but the Staudenmayer et al (105) paper are unable to find any such evidence in what they claim is an "evidence-based review". Collectively, there are dozens of obviously relevant and easily accessible studies supporting fulfilling one or more of the other eight Hill criteria for chemical causation of MCS, but Staudenmayer et al (105) cannot find any other them. This is despite the fact that substantial evidence was found previously for most of these in the influential Ashford and Miller (4) book.

We scientists are trained to try to cite all of the relevant literature in our papers and are trained to try to assess such relevant literature as objectively as possible. Sometimes, despite our best efforts, we miss one or two relevant citations. It is this author's view, that this paper (105) is probably the most egregious failure to objectively assess the scientific literature that I have seen in my decades of experience as a scientist. What this paper documents is the unacceptable bias of its authors.

Scientists are also trained to avoid emotion-laden rhetoric. Science should be based on well-structured theory, available evidence and sound logic. However, there are many examples of emotion laden rhetoric in the psychogenic literature, some of which you have seen above and others of which are shown in quotations in Chapter 13, ref. 5. I will not provide any further support for this criticism here.

Psychogenic advocates have noted that psychiatric symptoms are common in MCS patients and they have used this observation to argue for a psychogenic etiology for MCS. However such arguments are deeply flawed based on three criteria:

1. Firstly, such symptoms are found in some but not other MCS patients and many such patients have no past or current history of psychiatric illness (107,108), so that a psychogenic etiology cannot be argued on this basis for many MCS patients.
2. Secondly, it is intellectually bankrupt to focus on such psychiatric symptoms while ignoring the large number of symptoms and signs in MCS, discussed above, that cannot be understood as being produced by a psychogenic "mechanism" and, in addition ignoring the large numbers of genuine physiological diseases that show substantial comorbidity with MCS. Such genuine physiological diseases as cardiovascular disease, orthostatic

intolerance, tinnitus, asthma, and migraine have substantial comorbidities with MCS and also with related multisystem illnesses (5,38).

3. Thirdly, most serious chronic physiological diseases are characterized by substantial prevalences of psychiatric symptoms and it is clearly false logic to argue as a consequence of such increased psychiatric symptom prevalence, that these are psychogenic. For example, it is well established that both anxiety and depression are very common in people suffering from cancer (109-111) or rheumatoid arthritis (112,113) but that does not make either of these psychogenic diseases.

So we have here still another psychogenic argument which is based on a highly selective choice of consideration of evidence, as well as faulty logic.

Any scientific hypothesis must make testable predictions, that can be used to test and potentially falsify it. Such possible falsification must be present in order to distinguish a scientific hypothesis from a mythological story. However, it is extraordinarily difficult to find any testable predictions in the psychogenic literature. One rare, almost unique exception is the statement on page 20 of Staudenmayer's book (88), previously quoted above, states that "The core presupposition of psychogenic theory is that psychological factors *are necessary and sufficient* to account for the clinical presentations of EI patients. Psychogenic theory emphasizes belief, somatization, psychophysiologic stress and anxiety responses, and psychogenic etiology" (italics added). Staudenmayer, as was noted above, refers to MCS in his book as environmental illness or EI. So how do these predictions hold up? Clearly the prediction that psychological factors are sufficient to account for MCS is massively contradicted by the role of chemicals acting to produce toxicological responses via increased NMDA activity, by the 51 types of evidence that support various aspects of the NO/ONOO- cycle mechanism, by all of the very extensive animal model data also implicating a total 13 different aspects of the NO/ONOO- cycle model, all except possibly one of the studies on objectively measurable responses to low level chemical exposure in MCS and most importantly, the genetic data showing that chemicals are acting as toxicants in initiating cases of MCS. So it is clear that psychological factors are **not** sufficient. Are they necessary? Here again all of the best evidence argues that they are not. Specifically, the NO/ONOO- cycle model provides a detailed and generally well supported explanatory model of MCS. In addition to that, many of the

MCS patients have no evidence of psychological/psychiatric abnormalities and where they do show such signs, in most cases they often appear to be caused by the disease rather than causing it. In conclusion then, the prediction that psychological factors are sufficient is clearly falsified and there are also strong arguments for falsification of the prediction that they are necessary. Clearly, then, the psychogenic hypothesis should be rejected based on Staudenmayer's two predictions.

There is a second, implied prediction that Staudenmayer makes, on p. 14 of his book (88). He states that "Because not everyone is (equally) susceptible to contracting EI, individual differences require explanation. Host susceptibility as a biological construct is a truism. But is it reasonable to reframe known etiologic factors of illness susceptibilities mediating toxicogenic mechanisms for which there is no evidence?" (the term equally was not in the original quote and was added to make Staudenmayer's statement more defensible). Staudenmayer, in effect, is predicting that no mechanisms of genetic susceptibility will be found supporting a toxicogenic mechanism for MCS. We now have four different studies implicating, in total, six genes all of which have roles in the metabolism of chemicals implicated in MCS (11-14). These provide compelling evidence, as you have already seen, that chemicals are acting as toxicants in initiating cases of MCS. In Staudenmayer's terminology, these studies show that MCS is a toxicogenic disease, and is not, therefore, psychogenic.

In defense of Staudenmayer, none of these genetic studies had been performed when he was writing his book. Therefore, *based on this criterion alone*, his position at that time was defensible. However at this time (2009), it is clear that his position is completely untenable and that the genetic evidence provides unequivocal evidence that the psychogenic claims for MCS should be rejected based on his testable prediction.

In summary, psychogenic advocates rarely make clear predictions that can be used to test and potentially falsify their hypothesis. This must be viewed as a major flaw of psychogenesis, because any scientific hypothesis must make such clear predictions. Two rare predictive statements from Staudenmayer's book (88) can be tested however. The extensive evidence shows that psychogenesis is falsified by tests of both of these statements. Therefore, psychogenesis of MCS as advocated by Staudenmayer must be rejected.

Summary of Flaws of Psychogenesis

Psychogenic advocates of MCS and related illnesses have:

1. Ignored large amounts contrary evidence on the toxicological actions of chemicals otherwise implicated in MCS, on physiological changes occurring in patients suffering from MCS and related illnesses, on genetics of MCS susceptibility, on objectively measurable responses to low level chemical exposure in MCS patients, on animal models of MCS and on clinical trial studies of MCS-related illnesses.
2. Made sweeping inferences based on little or no data.
3. Based their hypothesis on the concepts of somatoform disorders and somatization, concepts that have substantial flaws in both theory and practice and have been increasingly questioned in the scientific literature.
4. Based their view on an assumed dualism between the psychological/psychiatric/mental on the one hand and the physical/physiological/biological on the other. This dualism has been rejected by modern science.
5. Made repeated logically flawed arguments.
6. Ignored the long history of false psychogenic attribution in medicine, a history that raises the question of whether they are making the same errors that led to false psychogenic claims in the past.
7. Based many of their publications on substantial amounts of emotion-laden rhetoric, rather than following good scientific practice of letting sound theoretical structure, sound evidence and sound logic lead their arguments.
8. Dismissed large bodies of contrary literature based on little or no evidence.
9. Typically failed to make testable predictions, predictions that can be used to test and potentially falsify their hypothesis. Two rare exceptions to this pattern make predictions that have been falsified and lead, therefore, to rejection of their hypothesis.

Each of these is a very serious flaw. Several of them alone, specifically numbers 1, 2, 5, 8 and 9, are in my judgement, more than sufficient reason to reject psychogenesis of MCS. The combination of all nine must be assessed as being devastating to any psychogenic claims.

Overall Summary and Areas of Greatest Research Need

More extensive documentation and discussion of many issues discussed in this paper can be found in ref. 1. There are two major scientific issues developed within this paper.

The first is focused on the role of chemicals acting as toxicants in MCS. That role is clearly established based on four types of evidence:

1. Each of the seven classes of chemicals implicated in initiating cases of MCS can act to increase NMDA activity in the body. For five of the seven classes of chemicals, the pathways of action leading to increased NMDA activity are well known. For the other two, hydrogen sulfide and carbon monoxide, the pathways are uncertain but the response is well documented.
2. In animal model studies it has been shown that NMDA antagonists can greatly lower the toxic response to members of all seven of these classes. This shows that not only does an NMDA increase occur in response to these chemicals, but that this increase is very important in producing the toxic responses to these chemicals.
3. There are six additional types of evidence implicating excessive NMDA activity in MCS, and suggesting that both initiating chemicals and chemicals triggering responses in those already sensitive appear to act via increased NMDA activity. Thus we have compelling evidence that this common toxicological response to these chemicals is central to the mechanism of MCS.
4. Four genetic studies have collectively implicated six genes in determining MCS susceptibility, with all six of these genes acting to determine the rate of metabolism of chemicals otherwise implicated in MCS. This provides powerful confirming evidence that chemicals are acting as toxicants in MCS.

These four types of evidence establish that chemicals are acting as toxicants in MCS. While that conclusion is not in any way dependent on the etiologic mechanism of MCS, it does provide substantial support for that etiologic mechanism.

This paper also describes a detailed apparent mechanism for MCS, called the NO/ONOO⁻ cycle. This vicious biochemical cycle mechanism explains, when fused with neural sensitization, neurogenic inflammation and other mechanisms, the many challenging aspects of this illness that had never been previously explained. Because, as Kuhn (114) has made clear, new scientific paradigms are tested, often largely, by their ability to explain the many previously unexplained aspects of a scientific field, the power of the NO/ONOO⁻ cycle as an explanatory model is of great importance. It is my view that the power of the NO/ONOO⁻ cycle fusion mechanism as an explanatory model in MCS, and the various aspects of the model that are well-supported experimentally support the inference that the overall model is likely to be fundamentally correct. However, it could certainly be wrong in one or more details and is almost certainly incomplete.

This proposed mechanism is supported by well established toxic mechanisms of action of the seven classes of chemicals implicated in initiating cases of MCS. All of seven of these can act to elevate NMDA activity and produce toxic responses in the human body through such NMDA elevation. The NO/ONOO⁻ cycle fusion model provides mechanisms for the generation of symptoms in MCS patients, both symptoms that are shared with such related illnesses as CFS, FM and PTSD and also chemical sensitivity symptoms that are viewed as being specific for MCS. It is supported by observations implicating excessive NMDA activity, excessive nitric oxide levels and oxidative stress, neural sensitization, elevated TRP receptor activity, elevated peroxynitrite levels and elevated levels of intracellular calcium in people afflicted with MCS, in animal models or both. While there has been little in the way of published studies on therapy for MCS, clinical trial data on the related illnesses CFS and FM provide support for the inference that such aspects of the cycle as excessive oxidative stress, nitric oxide, NMDA activity, mitochondrial dysfunction, inflammation and tetrahydrobiopterin depletion have important causal roles in the generation of this group of illnesses. We have some clinical observations suggesting that complex protocols designed to normalize these several parameters can produce substantial rapid improvement in many MCS patients who are also avoiding chemical exposure, even among patients who have been ill for decades.

Having said that, there are many aspects of this proposed MCS mechanism that need much study. That is not surprising, given the extraordinarily low level of funding that has been available for such studies. It has been estimated (9) that although MCS has a higher apparent prevalence than does diabetes in the U.S., the funding

available for research on MCS has been approximately 1/1000th of the funding for diabetes. This low level of funding is despite the fact that what data we have on comorbid diseases for MCS (5,32-35) and the substantial impact on employment of MCS patients both suggest that the morbidity associated with MCS and its associated comorbid diseases may be comparable to that found as a consequence of diabetes.

The six areas that are in most need of further study, in my judgment are:

1. Animal model studies testing various aspects of the NO/ONOO-cycle fusion mechanism that have never been tested or, at least, adequately tested. For example, we have no direct data, that the organic solvents act via the TRP group of receptors in MCS and this can be best tested in animal model studies.
2. Studies to establish one or more low level chemical exposure tests as specific biomarker tests for MCS. We have a number of promising such tests and it is tragic that these studies have not been carried further to establish several of them as specific biomarker tests.
3. Clinical trial studies on agents and groups of agents aimed at down-regulating various aspects of the proposed mechanism as potential therapeutic protocols for the treatment of MCS patients. Again, the NO/ONOO- cycle mechanism makes many useful predictions in terms of therapy and some of these have been confirmed, particularly in the related illnesses, CFS/ME and FM. What we need now, is study on how combinations of agents may produce substantial improvements and possibly also some cures.
4. Studies of some of these same agents in placebo-controlled studies to determine if they can lower responses to low level chemical exposure in MCS patients. These might be done in conjunction with the specific biomarker tests in #2.
5. Use of bioassays described above to ascertain likely chemicals in the air of mold infested "sick buildings" to determine what mycotoxins are involved and also what molds produce them under what culture conditions. This is an area of concern that was discussed in ref. 1 but not in this paper. Many examples of "sick buildings" leading inhabitants to develop multiple cases of MCS have been reported to be mold-infested buildings. However, our ignorance about mechanisms here is profound and we specifically need to know what mycotoxins are involved. Promising methods have been developed for such bioassays

- (76,115,116) that may be used to detect such mycotoxins but how well these will work in practice is uncertain. We are still plagued by many examples of such "sick buildings" due in part to our stunning ignorance about the mycotoxins involved and their mechanisms of action.
6. We need extensive studies of comorbid diseases in MCS, because the whole spectrum of pathophysiology associated with MCS has been little explored. Specifically I predict that such diseases as Parkinson's, amyotrophic lateral sclerosis and multiple sclerosis may well be comorbid with MCS but these have never been studied. Cancer comorbidity has been reported for CFS, but never been studied for MCS. There are many other diseases that should be studied, as well, including the several diseases for which we already have some evidence for comorbidity.

References Cited:

1. Pall ML (2009) Multiple Chemical Sensitivity: Toxicological Questions and Mechanisms. Chapter XX in General and Applied Toxicology, Bryan Ballantyne, Timothy C. Marrs, Tore Syversen, Eds., John Wiley & Sons, London.
2. Miller CS (1997) Toxicant-induced loss of tolerance—an emerging theory of disease? *Environmental Health Perspectives* 105, 445–453.
3. Cullen MR (1987) The worker with multiple chemical sensitivities: an overview. *Occup Med* 2,655-661.
4. Ashford N, Miller C (1998) *Chemical Exposures: Low Levels and High Stakes*, 2nd edition. John Wiley & Sons, New York.
5. Pall ML (2007) Explaining "Unexplained Illnesses": Disease Paradigm for Chronic Fatigue Syndrome, Multiple Chemical Sensitivity, Fibromyalgia, Post-Traumatic Stress Disorder, Gulf War Syndrome and Others. Harrington Park (Haworth) Press, New York.
6. Miller CS (2000) Mechanisms of action of addictive stimuli. *Addiction* 96, 115–139.
7. Gots RE 1996 Multiple chemical sensitivities: distinguishing between psychogenic and toxicodynamic. *Regul Toxicol Pharmacol* 24,S8-S15.
8. Miller CS, Mitzel HC (1995) Chemical sensitivity attributed to pesticide exposure versus remodeling. *Arch Environ Health* 50,398-402.
9. Pall ML (2002) NMDA sensitization and stimulation by peroxynitrite, nitric oxide and organic solvents at the mechanism of

chemical sensitivity in multiple chemical sensitivity. *FASEB J* 16,1407-1417.

10. Pall ML (2003) Elevated nitric oxide/peroxynitrite theory of multiple chemical sensitivity: central role of N-methyl-D-aspartate receptors in the sensitivity mechanism. *Environ Health Perspect* 111,1461-1464.

11. Haley RW, Billecke S, La Du BN (1999) Association of low PON1 type Q (type A) arylesterase activity with neurologic symptom complexes in Gulf War veterans. *Toxicol Appl Pharmacol* 157,227-233.

12. McKeown-Eyssen G, Baines C, Cole DE, Riley N, Tyndale RF, Marshall L, Jazmaji V (2004) Case-control study of genotypes in multiple chemical sensitivity: CYP2D6, NAT1, NAT2, PON1, PON2 and MTHFR. *Int J Epidemiol* 33,971-978.

13. Schnakenberg E, Fabig KR, Stanulla M, Strobl N, Lustig M, Fabig N, Schloot W (2007) A cross-sectional study of self-reported chemical-related sensitivity is associated with gene variants of drug-metabolizing enzymes. *Environ Health*. 6,6-16.

14. Müller KE, Schnakenberg E (2008) Die Bedeutung der Glukuronidierung bei umweltmedizinischen Erkrankungen am Beispiel der UDP-Glukuronosyltransferase 1A1. *Umwelt Medizin Gesellschaft* 21(4): 295-300

15. Axel R 2005 Scents and sensibility: a molecular logic of olfactory perception (Nobel lecture). *Angew Chem Int Ed Engl* 44,6110-6127.

16. Buck L.B. (2005) Unraveling the sense of smell (Nobel lecture). *Angew Chem Int Ed Engl* 44,6128-6140.

17. Hillert L, Musabasic V, Berglund H, Ciumas C, Savic I. 2007 Odor processing in multiple chemical sensitivity. *Hum Brain Mapp* 28,172-182.

18. Forder JP, Tymianski M (2009) Postsynaptic mechanisms of excitotoxicity: Involvement of postsynaptic density proteins, radicals, and oxidant molecules. *Neuroscience* 158, 293-300.

19. Dawson VL, Dawson TM (2004) Deadly conversations: nuclear-mitochondrial cross-talk. *J Bioenerg Biomembr* 36, 287-294.

20. Pall ML 2009 The NO/ONOO- Vicious Cycle Mechanism as the Cause of Chronic Fatigue Syndrome/Myalgic Encephalomyelitis. In: *Chronic Fatigue Syndrome: Symptoms, Causes and Prevention*, Svoboda and Kristof Zelenjick, Eds. Nova Biomedical Publishers, New York, in press.

21. Pall ML (2007) Nitric oxide synthase partial uncoupling as a key switching mechanism for the NO/ONOO- cycle. *Med Hypotheses* 69, 821-825.

22. Heuser G, Mena I, Alamos F (1994) NeuroSPECT findings in patients exposed to neurotoxic chemicals. *Toxicol Ind Health* 10,561-571.

23. Simon TR, Hickey DC, Fincher CE, Johnson AR, Ross GH, Rea WJ (1994) Single photon emission computed tomography of the brain in patients with chemical sensitivities. *Toxicol Ind Health* 10,573-577.
24. Fincher CE, Chang TS, Harrell EH, Kettelhut MC, Rea WJ, Johnson A, Hickey DC, Simon TR (1997) Comparison of single photon emission computed tomography findings in cases of healthy adults and solvent-exposed adults. *Am J Ind Med* 31,4-14.
25. Fincher CE, Chang TS, Harrell EH, Kettelhut MC, Rea WJ, Johnson A, Hickey DC, Simon TR (1997) Comparison of single photon emission computed tomography findings in cases of healthy adults and solvent-exposed adults: Correction of previous results. *Am J Ind Med* 32,693-694.
26. Heuser G, Wu JC (2001) Deep subcortical (including limbic) hypermetabolism in patients with chemical intolerance: human PET studies. *Ann N Y Acad Sci* 933,319-322.
27. Sorg BA 1999 Multiple chemical sensitivity: potential role for neural sensitization. *Crit Rev Neurobiol* 13,283-316.
28. Pall ML 2005 Multiple chemical sensitivity: towards the end of controversy. *Townsend Lett Doctors Patients* Aug/Sept 2005, 52-56.
29. McKeown-Eyssen GE, Baines CJ, Marshall LM, Jazmaji V, Sokoloff ER (2001) Multiple chemical sensitivity: discriminant validity of case definitions. *Arch Environ Health* 56,406-412.
30. MCS Consensus Conference 1999 Multiple chemical sensitivity: a 1999 consensus. *Arch Environ Health* 54,147-149.
31. Caress SM, Steinemann AC (2004) A national population study of the prevalence of multiple chemical sensitivity. *Arch Environ Health* 59,300-305.
32. Baldwin CM, Bell IR (1998) Increased cardiopulmonary disease risk in a community-based sample with chemical odor intolerance: implications for women's health and health-care utilization. *Arch Environ Health* 53,347-353.
33. Bell IR, Peterson JM, Schwartz GE (1995) Medical histories and psychological profiles of middle-aged women with and without self-reported chemical intolerance. *J Clin Psychiatry* 56,151-160.
34. Baldwin CM, Bell IR, O'Rourke MK, Lebowitz MD (1997) The association of respiratory problems in a community sample with self-reported chemical intolerance. *Eur J Epidemiol* 13,547-552.
35. Baldwin CM, Bell IR, O'Rourke MK (1999) Odor sensitivity and respiratory complaint profiles in a community-based sample with asthma, hay fever, and chemical odor intolerance. *Toxicol Ind Health* 15,403-409.
36. Bell IR, Schwartz GE, Baldwin CM, Hardin EE (1996) Neural sensitization and physiological markers in multiple chemical sensitivity. *Regul Toxicol Pharmacol* 24(1 Pt 2),S39-S47.

37. Bell IR, Baldwin CM, Russek LG, Schwartz GE, Hardin EE (1998) Early life stress, negative paternal relationships, and chemical intolerance in middle-aged women: support for a neural sensitization model. *J Womens Health* 7,1135-1147.
38. Bell IR, Baldwin CM, Fernandez M, Schwartz GE (1999) Neural sensitization model for multiple chemical sensitivity: overview of theory and empirical evidence. *Toxicol Ind Health* 15,295-304.
39. Bell IR, Baldwin CM, Schwartz GE (2001) Sensitization studies in chemically intolerant individuals: implications for individual difference research. *Ann N Y Acad Sci* 933,38-47.
40. Antelman SM (1994) Time-dependent sensitization in animals: a possible model of multiple chemical sensitivity in humans. *Toxicol Ind Health* 10,335-342.
41. Rossi J 3rd (1996) Sensitization induced by kindling and kindling-related phenomena as a model for multiple chemical sensitivity. *Toxicology* 111,87-100.
42. Novelli A, Reilly JA, Lysko PG, Henneberry RC (1988) Glutamate becomes neurotoxic via the N-methyl-D-aspartate receptor when intracellular energy levels are reduced. *Brain Res* 451,205-212.
43. Schulz JB, Matthews RT, Klockgether T, Dichgans J, Beal MF (1997) The role of mitochondrial dysfunction and neuronal nitric oxide in animal models of neurodegenerative diseases. *Mol Cell Biochem* 174,193-197.
44. Turski L, Turski WA (1993) Towards an understanding of the role of glutamate in neurodegenerative disorders: energy metabolism and neuropathology. *Experientia* 49,1064-1072.
45. Gadea A, Lopez-Colome AM (2001) Glial transporters for glutamate, glycine and GABA I. Glutamate transporters. *J Neurosci Res* 63,456-460.
46. Bliss TM, Ip M, Cheng E, et al. 2004 Dual-gene, dual-cell therapy against excitotoxic insult by bolstering neuroenergetics. *J Neurosci* 24,6202-6208.
47. Fiedler N, Kipen HM (2001) Controlled exposures to volatile organic compounds in sensitive groups. *Ann N Y Acad Sci* 933:24-37.
48. Phares TW, Fabis MJ, Brimer CM, Kean RB, Hooper DC (2007) A peroxynitrite-dependent pathway is responsible for blood-brain barrier permeability changes during a central nervous system inflammatory response: TNF-alpha is neither necessary nor sufficient. *J Immunol* 178,7334-7343.
49. Kuklinski B, Scheifer R, Bleyer H (2003) Hirnschrankenprotein S-100 und xenobiotica-susceptibilitat. *Umwelt Medizin Gesellschaft* 16,112-120.
50. Abdel-Rahman A, Shetty AK, Abou-Donia MB (2002) Disruption of the blood-brain barrier and neuronal cell death in cingulate cortex,

dentate gyrus, thalamus, and hypothalamus in a rat model of Gulf-War syndrome. *Neurobiol Dis* 10,306-326.

51. Abu-Qare AW, Abou-Donia MB (2003) Combined exposure to DEET (N,N-diethyl-m-toluamide) and permethrin: pharmacokinetics and toxicological effects. *J Toxicol Environ Health B Crit Rev* 6,41-53.
52. Abou-Donia MB, Dechkovskaia AM, Goldstein LB, Bullman SL, Khan WA (2002) Sensorimotor deficit and cholinergic changes following coexposure with pyridostigmine bromide and sarin in rats. *Toxicol Sci* 66,148-158.
53. Meggs WJ (1993) Neurogenic inflammation and sensitivity to environmental chemicals. *Environ Health Perspect* 101,234-238.
54. Meggs WJ (1994) RADS and RUDS--the toxic induction of asthma and rhinitis. *J Toxicol Clin Toxicol* 32,487-501.
55. Meggs WJ (1997) Hypothesis for induction and propagation of chemical sensitivity based on biopsy studies. *Environ Health Perspect* 105 Suppl 2,473-478.
56. Meggs WJ, Elsheik T, Metzger WJ, Albernaz M, Bloch RM (1996) Nasal pathology and ultrastructure in patients with chronic airway inflammation (RADS and RUDS) following an irritant exposure. *J Toxicol Clin Toxicol* 34,383-396.
57. Bascom R, Meggs WJ, Frampton M, Hudnell K, Kilburn K, Kobal G, Medinsky M, Rea W (1997) Neurogenic inflammation: with additional discussion of central and perceptual integration of nonneurogenic inflammation. *Environ Health Perspect* 105 Suppl 2:531-537.
58. Leffler A, Fischer MJ, Rehner D, Kienel S, Kistner K, Sauer SK, et al. (2008) The vanilloid receptor TRPV1 is activated and sensitized by local anesthetics in rodent sensory neurons. *J Clin Invest* 118,763-776.
59. Kajekar R, Moore PK, Brain SD (1995) Essential role for nitric oxide in neurogenic inflammation in rat cutaneous microcirculation. Evidence for an endothelium-independent mechanism. *Circ Res* 76,441-447.
60. Yonehara N, Yoshimura M (1999) Effect of nitric oxide on substance P release from the peripheral endings of primary afferent neurons. *Neurosci Lett* 271,199-201.
61. Ruocco I, Cuello AC, Shigemoto R, Ribeiro-da-Silva A (2001) Light and electron microscopic study of the distribution of substance P-immunoreactive fibers and neurokinin-1 receptors in the skin of the rat lower lip. *J Comp Neurol* 432,466-480.
62. Pall ML, Anderson JH (2004) The vanilloid receptor as a putative target of diverse chemicals in multiple chemical sensitivity. *Arch Environ Health* 59,363-372.
63. Lieb K, Fiebich BL, Berger M, Bauer J, Schulze-Osthoff K (1997) The neuropeptide substance P activates transcription factor NF-kappa

- B and kappa B-dependent gene expression in human astrocytoma cells. *J Immunol* 159,4952-4958.
64. Heuser G (2000) Letter to the editor regarding "mast cell disorder to be ruled out in MCS". *Arch Environ Health* 55,284-285.
65. Heuser G (2001) The role of the brain and mast cells in MCS. *Townsend Lett Doctors Patients* 210,74-75.
66. Kimata H. (2004) Effect of exposure to volatile organic compounds on plasma levels of neuropeptides, nerve growth factor and histamine in patients with self-reported multiple chemical sensitivity. *Int J Hyg Environ Health* 207,159-163.
67. Hu CL, Xiang JZ, Hu FF (2008) Vanilloid receptor TRPV1, sensory C-fibers, and activation of adventitial mast cells. A novel mechanism involved in adventitial inflammation. *Med Hypotheses* 71,102-103.
68. Kempuraj D, Huang M, Kandere-Grzybowska K, Basu S, Boucher W, Letourneau R, Athanassiou A, Theoharides TC (2003) Azelastine inhibits secretion of IL-6, TNF-alpha and IL-8 as well as NF-kappaB activation and intracellular calcium ion levels in normal human mast cells. *Int Arch Allergy Immunol* 132,231-239.
69. Lee SH, Park HH, Kim JE, Kim JA, Kim YH, Jun CD, Kim SH (2007) Alloose gallates suppress expression of pro-inflammatory cytokines through attenuation of NF-kappaB in human mast cells. *Planta Med* 73,769-773.
70. Kamei J, Tanihara H, Igarashi H, Kasuya Y (1989) Effects of N-methyl-D-aspartate antagonists on the cough reflex. *Eur J Pharmacol* 168,153-158.
71. Chung KF (2005) Pathophysiology and therapy of chronic cough. *Minerva Med* 96,29-40.
72. Johansson A, Millqvist E, Nordin S, Bende M (2006) Relationship between self-reported odor intolerance and sensitivity to inhaled capsaicin: proposed definition of airway sensory hyperreactivity and estimation of its prevalence. *Chest* 129,1623-1628.
73. Schwartz GE, Bell IR, Dikman ZV, Fernandez M, Kline JP, Peterson JM, Wright KP (1994) EEG responses to low-level chemicals in normals and cacosmics. *Toxicol Ind Health* 10,633-643.
74. Joffres MR, Sampalli T, Fox RA (2005) Physiologic and symptomatic responses to low-level substances in individuals with and without chemical sensitivities: a randomized controlled blinded pilot booth study. *Environ Health Perspect* 113,1178-1183.
75. Peden DB (1996) The use of nasal lavage for objective measurement of irritant-induced nasal inflammation. *Regul Toxicol Pharmacol* 24(1 Pt 2):S76-S78.
76. Hirvonen MR, Nevalainen A, Makkonen N, Mönkkönen J, Savolainen K (1997) Induced production of nitric oxide, tumor necrosis factor, and interleukin-6 in RAW 264.7 macrophages by

- streptomycetes from indoor air of moldy houses. Arch Environ Health 52,426-432.
77. Morrow LA, Ryan CM, Hodgson MJ, Robin N (1990) Alterations in cognitive and psychological functioning after organic solvent exposure. J Occup Med 32:444-450.
78. McKeown-Eyssen GE, Baines CJ, Marshall LM, Jazmaji V, Sokoloff ER (2001) Multiple chemical sensitivity: discriminant validity of case definitions. Arch Environ Health 56,406-412.
79. Zibrowski EM, Robertson JM (2006) Olfactory sensitivity in medical laboratory workers occupationally exposed to organic solvent mixtures. Occup Med (Lond) 56,51-54.
80. Maschewsky W (1996) Handbuch Chemikalien-Unverträglichkeit (MCS). MediVerlag, Hamburg.
81. Maschewsky W. (2002)
<http://www.elc.org.uk/papers/2002maschewsky.doc>
82. Yu IT, Lee NL, Zhang XH, Chen WQ, Lam YT, Wong TW (2004) Occupational exposure to mixtures of organic solvents increases the risk of neurological symptoms among printing workers in Hong Kong. J Occup Environ Med 46,323-330.
83. Moen B, Hollund B, Riise T (2008) Neurological symptoms among dental assistants: a cross-sectional study. J Occup Med Toxicol 18,10.
84. Binder LM, Campbell KA (2004) Medically unexplained symptoms and neuropsychological assessment. J Clin Exp Neuropsychol 26,369-392.
85. Kilburn, KH (1998) Chemical brain injury. New York : Van Nostrand Reinhold.
86. Feldman RG (1999) Occupational & Environmental Neurotoxicology. Lippincott-Raven, Philadelphia.
87. Marrs, TC, Ballantyne, B, Eds (2004) Pesticide Toxicology and International Regulation. John Wiley and Sons, London.
88. Staudenmayer H. Environmental Illness: Myth and Reality. (1999) Lewis Publishers, Boca Raton, FL.
89. Staudenmayer H. (1996) Clinical consequences of the EI/MCS "diagnosis": two paths. Regul Toxicol Pharmacol 24,S96-S110.
90. Stanley I, Salmon P, Peters S (2002) Doctors and social epidemics: the problem of persistent unexplained physical symptoms, including chronic fatigue. Br J Gen Pract 52,355-356.
91. Pall ML (2002) Chronic fatigue syndrome/myalgic encephalomyelitis. Br J Gen Pract 52,762.
92. Stanley I, Salmon P, Peters S (2002) Authors' response. Br J Gen Pract 52,763-764.
93. Smith GR (1990) Somatization disorder in the medical setting. U.S. Dept. of Health and Human Services, Public Health Service,

- Alcohol, Drug Abuse, and Mental Health Administration, National Institute of Mental Health, Bethesda, MD.
94. American Psychiatric Association, Diagnostic and Statistical Manual of Mental Disorders, 4th edition, DSM-IV, American Psychiatric Press, Washington D.C., 1994.
 95. Janca A (2005) Rethinking somatoform disorders. *Curr Opin Psychiatry* 18,65-71.
 96. Epstein RM, Quill TE, McWhinney IR (1999) Somatization reconsidered: Incorporating the patients experience of illness. *Arch Intern Med* 159,215-222.
 97. Deary V (2005) Explaining the unexplained? Overcoming the distortions of a dualist understanding of medically unexplained illness. *J Mental Health* 14,213-221.
 98. Mayou R, Kirmayer IJ, Simon G, Kroenke K, Sharpe M (2005) Somatoform disorders: time for a new approach in DSM-V. *Am J Psychiatry* 162,847-855.
 99. Black DW (2002) Paroxetine for multiple chemical sensitivity. *Am J Psychiatry* 159,1436-1437.
 100. Das-Munshi J, Rubin GJ, Wessely S (2007) Multiple chemical sensitivities: review. *Curr Opin Otolaryngol Head Neck Surg* 15,274-280.
 101. Baines CJ, McKeown-Eyssen GE, Riley N, Cole DE, Marshall L, Loescher B, Jazmaji V (2004) Case-control study of multiple chemical sensitivity, comparing haematology, biochemistry, vitamins and serum volatile organic compound measures. *Occup Med (Lond)* 54,408-418.
 102. Kanaan RA, Lepine JP, Wessely SC. (2007) The association or otherwise of the functional somatic syndromes. *Psychosom Med* 69,855-859.
 103. Barsky AJ, Borus JF (1999) Functional somatic syndromes. *Ann Intern Med* 130,910-921.
 104. Wessely S, Nimnuan C, Sharpe M. (1999) Functional somatic syndromes: one or many? *Lancet* 354,936-939.
 105. Staudenmayer H., Binkley K.E., Leznoff A., Phillips S. (2003) Idiopathic environmental intolerance Part 1: A causation analysis applying Bradford Hill's criteria to the toxicogenic theory. *Toxicol Rev* 22,235-246.
 106. Hill AB (1965) The environment and disease: association or causation? *Proc R Soc Med* 58:295-300.
 107. Simon GE, Daniell W, Stockbridge H, Claypool K, Rosenstock L (1993) Immunologic, psychological and neuropsychological factors in multiple chemical sensitivity: A controlled study. *Am J Psychiatry* 41, 97-103.

108. Fiedler N, Kipen HM, Deluca J, Kelly-McNeil K, Natelson B (1996) A controlled comparison of multiple chemical sensitivities and chronic fatigue syndrome. *Psychosom Med* 58, 38-49.
109. Epping-Jordan JE, Compas BE, Osowiecki G et al. (1999) Psychological adjustment to breast cancer: processes of emotional distress. *Health Psychol* 18, 315-326.
110. Sheard T, Maguire P (1999) The effect of psychological interventions on anxiety and depression in cancer patients. results of two meta-analyses. *Brit J Cancer* 80, 1770-1780.
111. Moorey S, Greer S, Watson M, Gorman C, Rowden L, Tunmore R, Robertson B, Bliss J (1991) The factor structure and factor stability of the hospital anxiety and depression scale in patients with cancer. *Br J Psychiatry* 158,255-259.
112. Hawley DJ, Wolfe F (1988) Anxiety and depression in patients with rheumatoid arthritis: a prospective study of 400 patients. *J Rheumatol* 15, 932-941.
113. Pincus T, Griffith J, Cantor S, Torresin W. Prevalence of self-reported depression in patients with rheumatoid arthritis. *Clin Exp Rheumatol* 5, 147-150.
114. Kuhn, TS (1996) *The Structure of Scientific Revolutions*, 3rd edition. University of Chicago Press, Chicago.
115. Hirvonen MR, Nevalainen A, Makkonen N, Mönkkönen J, Savolainen K (1997) Induced production of nitric oxide, tumor necrosis factor, and interleukin-6 in RAW 264.7 macrophages by streptomycetes from indoor air of moldy houses. *Arch Environ Health* 52,426-432.
116. Ruotsalainen M, Hyvärinen A, Nevalainen A, Savolainen KM (1995) Production of reactive oxygen metabolites by opsonized fungi and bacteria isolated from indoor air, and their interactions with soluble stimuli, fMLP or PMA. *Environ Res* 69,122-131.